



Read the user manual carefully before using the device! Responsibility for any damage, loss or accidents to persons arising from failure to comply with the warnings in the user manual belongs to the user. In case of malfunctions in this case, the device will be out of warranty.

ESDC3034

Split Digital Thermostat

- On-off cooling control,
- 4 relay outputs for compressor, defrost, fan, and aux,
- 3 NTC probe inputs for cabinet, evaporator, condenser,
- Ability to enter offset values for probe inputs,
- 2 digital inputs for door control and multifunction use,
- Ability to adjust lower and upper limits of the set value,
- Compressor protection parameters,
- Ability to adjust the operation, stopping, or periodic operation of the compressor in case of probe failures,
- Manual rapid cooling/heating feature,
- Time and evaporator temperature-dependent or manual defrost feature,
- Ability to adjust defrost duration and interval,
- Adjustable lower and upper alarm limits,
- Ability to keep maximum of 3 HACCP alarm records,
- Temperature display in °C or °F feature,
- RS485 Modbus RTU communication feature,
- Audible alarm capability,
- CE marked according to EN standards.



ORDER CODE: ESDC3034
ESDC-PWR (Only for control module)

Technical Specifications

Electrical Specifications

Supply Voltage	User interface: Powered by the control module Control module: 230V AC (+%10 -%20), 50/60Hz, max. 8VA
Connection Method	User interface: Plug-in screw terminal blocks for wires up to 1.75 mm ² Control module: Fixed screw terminal blocks for up to 2.5mm ² and 1.75 mm ²
Connection Cable Length	10m
Pollution Degree	2
Overvoltage Category	II
EMC-LVD	EN 61326-1:2021 - LVD: EN 61010-1: 2010

Environmental Specifications

Ambient/Storage Temperature	0 ...+50°C / -25 ...70°C (without frost)
Relative Humidity	Up to 80% humidity at 31°C, linearly decreasing to 50% at 40°C.
Protection Class	User interface: Front panel: IP65, Rear panel: IP20 according to EN 60529 Control module: IP00 According to EN 60529
Height	Max. 2000m



It should be used in environments where flammable and corrosive gases are not present.

Analog Inputs

Sensor Type	3 NTC probes (cabinet, evaporator, condenser)
Measurement Range	-50.0 ...+150.0°C (-58 ...+302°F)
Resolution	0.1°C (1°F)
Accuracy	±1°C

Digital Inputs

Contact Type	2 dry contacts (door input, multifunctional input)
--------------	--

Outputs

Compressor Relay Output	For resistive load: NO 250V AC 16A, for inductive load: 1/2hp 240V AC Relay life: Without load 30.000.000 switching, 250V AC 16A for resistive load 100.000 switching
Defrost Relay Output	For resistive load: NO 250V AC 8A, NC 250V AC 8A For inductive load: 1/2hp 240V AC Relay life: Without load 30.000.000 switching, 250V AC 8A for resistive load 100.000 switching
Evaporator Fan Relay Output	For resistive load: NO 250V AC 10A Relay life: Without load 30.000.000 switching, 250V AC 10A for resistive load 100.000 switching
Evaporator Fan Relay Output	For resistive load: NO 250V AC 5A Relay life: Without load 5.000.000 switching, 250V AC 5A for resistive load 100.000 switching

Control

Control Type	Control of compressor, evaporator fan, defrost and auxiliary output (AUX) with set values and digital inputs
--------------	--

Box

Material	User interface: Self-extinguishing plastics Control module: Open frame board
Dimensions	User interface: User Interface: 75 x 33 x 39.5 mm Control module: 115 x 75 mm
Weight	Approx. 540g (after packing)



The device should not be wiped with cleaning substances containing solvents (such as thinner, gasoline, acid, etc.) or abrasive cleaning agents.

Connection Diagram



ESDC3034 is a panel type defrost control device. The device must be used in accordance with the instructions. Installation and electrical connections must be carried out by technical personnel in accordance with the instructions in the user manual. During installation, care must be taken to ensure that there is no electricity. The device must be protected from humidity, vibration, and pollution. Operating temperature should be observed. Installation cables should not pass near high-power lines or other devices.

User Interface

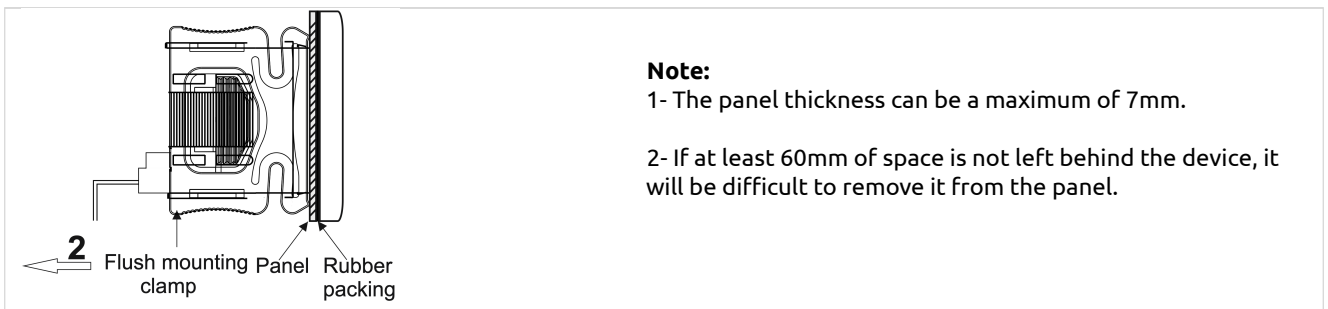
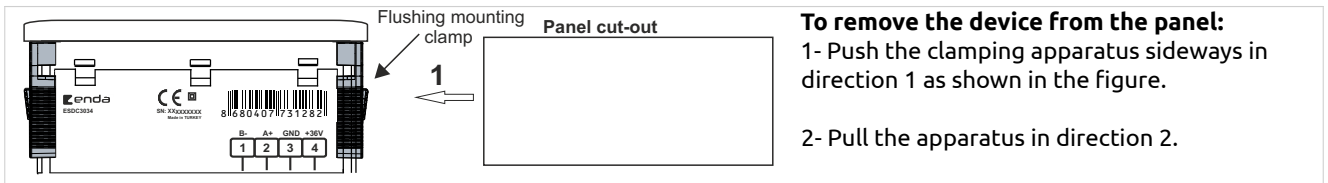

Control Module

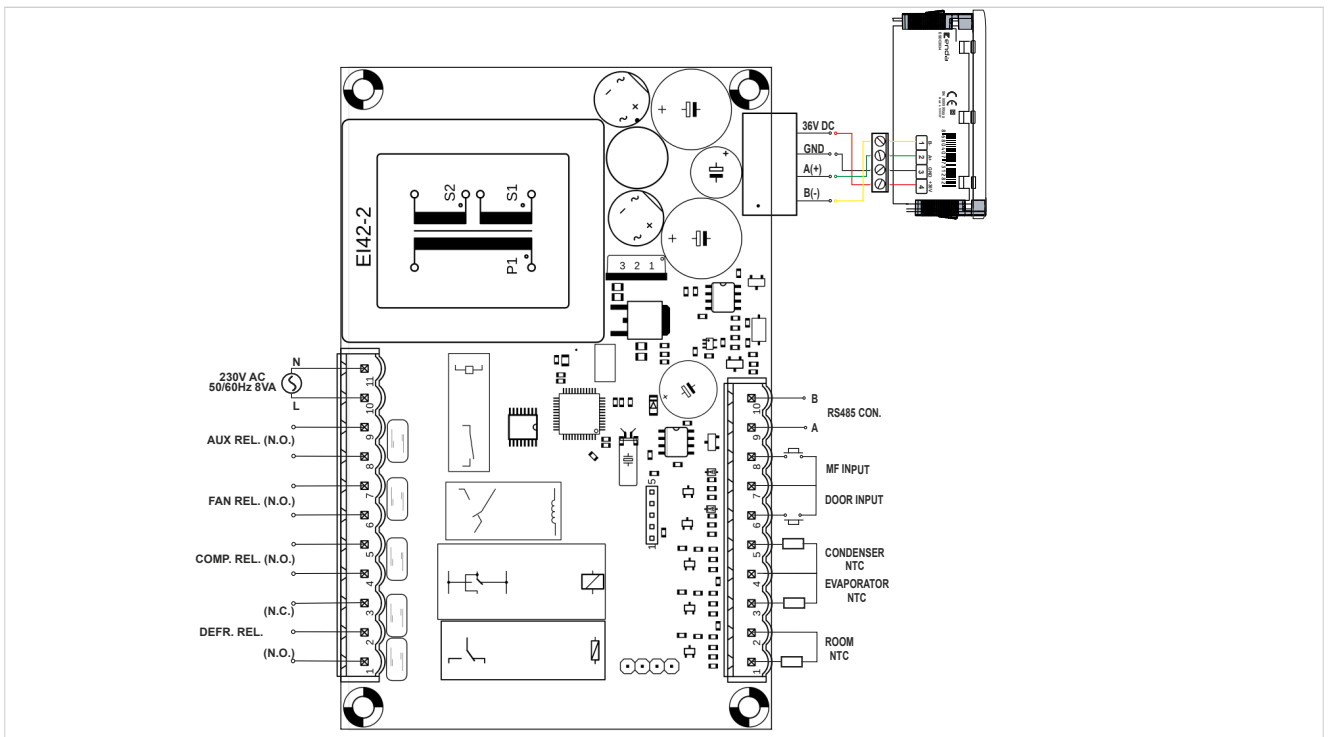

Supply Voltage:
 184-253V AC 50/60Hz 8VA

Line 10
 Neutral 11

Fuse F 100 mA 250V AC
 Switch
 230V AC Supply

Fuse should be connected. Cable size: 1,5mm²

Note:
 1) Mains supply cords shall meet the requirements of IEC 60227 or OEC 60245.
 2) In accordance with the safety regulations, the power supply switch shall bring the identification of the relevant instrument and it should be easily accessible by the operator.

Equipment is protected throughout by **DOUBLE INSULATION**

Holding screw 0.4-0.5Nm.

Dimensions and Assembly

User Interface:

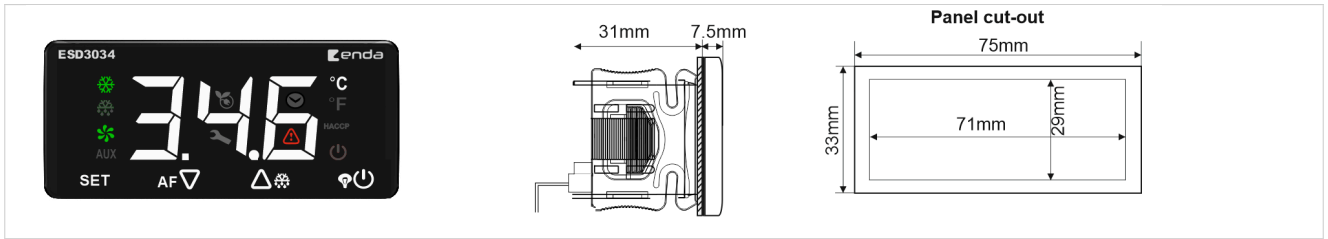

Control Module:

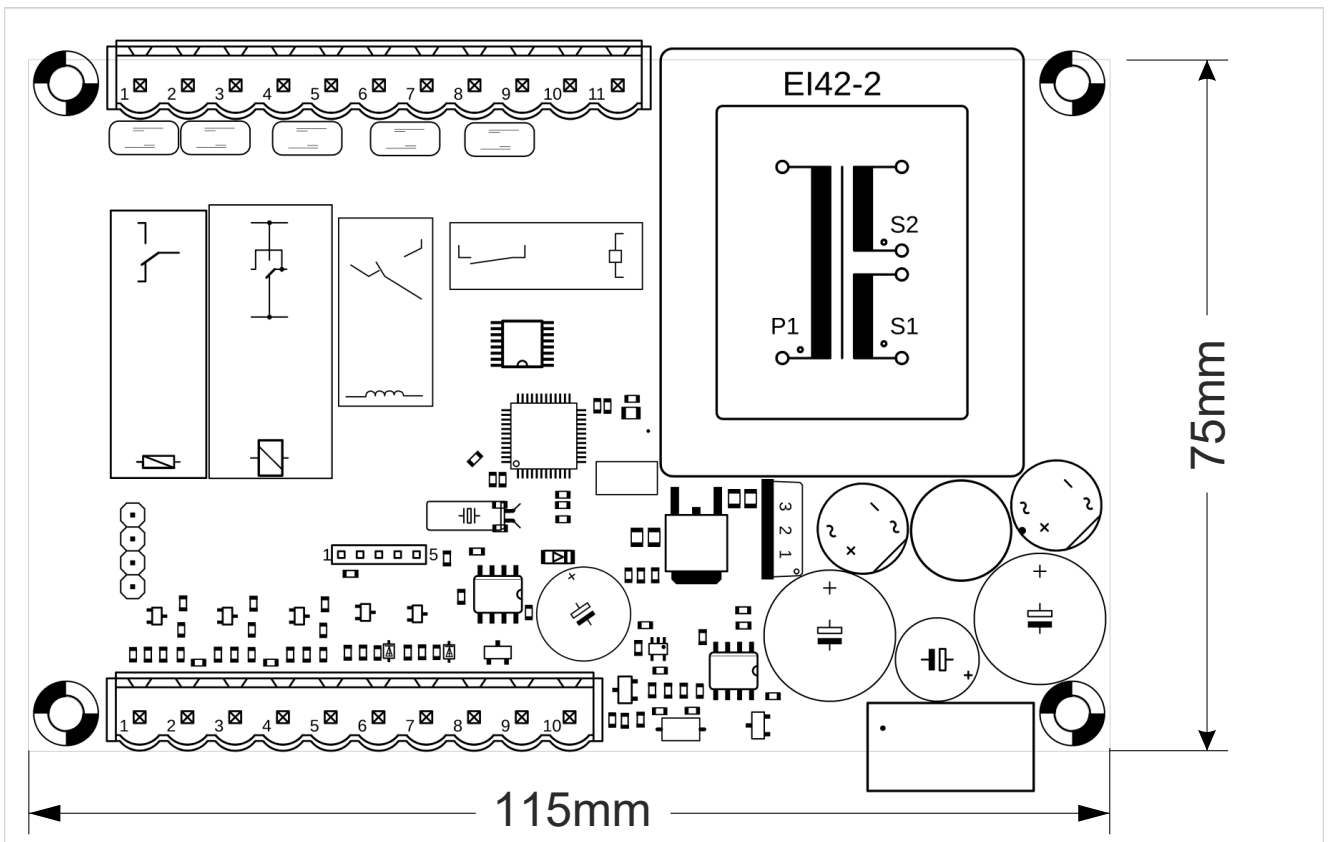

Panel Commands

Viewing and Changing Set Value



In working mode, pressing the **SET** key displays the set value, and the set value can be changed using the buttons.

Displaying Evaporator and Condenser Temperatures



In working mode (when the key lock is not active), if you press and hold the **SET** key and then the key together for 4 seconds, you will enter the menu where alarms and other information are displayed. From there, you can display **Pb2** (evaporator temperature) and **Pb3** (condenser temperature) by pressing the **SET** key. If no key is pressed for 60 seconds or the key is pressed, the device will return to working mode.

Locking and Unlocking Keys

If no key is pressed for 60 seconds in working mode, the message **LOC** will be displayed on the screen and the keys will be locked. If any key is pressed for 2 seconds while the keys are locked, the message **UNL** will be displayed on the screen and the key lock will be released.

Manual Defrost

If the key is pressed for 4 seconds in the "Running Mode", the defrost process is started or stopped manually.

1- If parameter **d3** = 0, manual defrost is also disabled.

2- Defrost will not start if the measurement value of the evaporator probe is greater than the value in the **d2** parameter.

Fast Cooling/Heating Operation

If the key is pressed for 2 seconds in the "Running Mode",
if **r5** is 0 and **r8** = 1 it starts overcooling ($\Delta P = \Delta P - r6$ for **r7** time),
if **r5** is 1 and **r8** = 1 it starts over heating ($\Delta P = \Delta P + r6$ for **r7** time)



Energy Saving

If the key is pressed for 2 seconds in the "Running Mode", if **r5** is 0 and **r8** = 2 it starts energy saving.
($\Delta P = \Delta P + r4$ for max **HE2** time)

Activating the Lighting Output

In operating mode, when $\square \uparrow = 0$ is selected, pressing the **SET** button to display the set value, followed by pressing the  button, will activate or deactivate the lighting output.

Manual On/Off Control of the Device

If the  key is pressed for 3 seconds in the "Running Mode" (without the key lock), the display turns off, temperature measurement and control are not performed, the output becomes passive. If the  key is pressed again for 3 seconds, the display turns on and the device continues to measure and control the temperature.

Turning Off the Audible Alarm

The buzzer sounds if an alarm condition occurs. The alarm/warning buzzer can be silenced by pressing any key. (if $\square \uparrow$ is 1)

Displaying Active Alarms

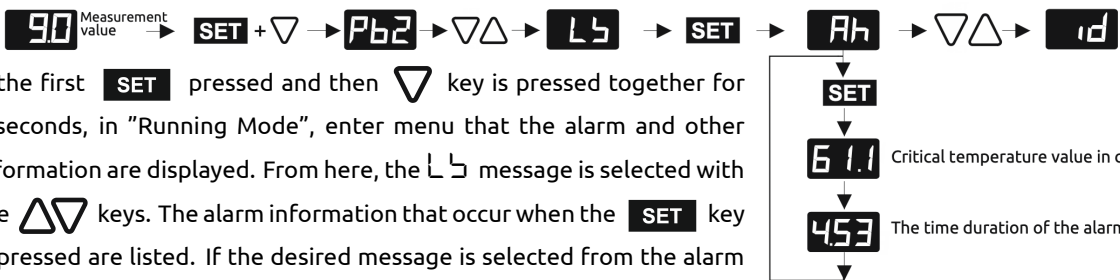

If the first **SET** pressed and then ∇ key is pressed together for 4 seconds, in "Running Mode", enter menu that the alarm and other information are displayed. From here, the $L5$ message is selected with the $\triangle \nabla$ keys. The alarm information that occur when the **SET** key is pressed are listed. If the desired message is selected from the alarm messages generated by the $\triangle \nabla$ keys and the **SET** key is pressed, the information of the relevant alarm is started to displayed in order. 15 seconds no key is pressed or the operation mode is restored if  key is pressed. The display time for each alarm is 99 hours, 9 minutes (99:9).

Deleting Active Alarms

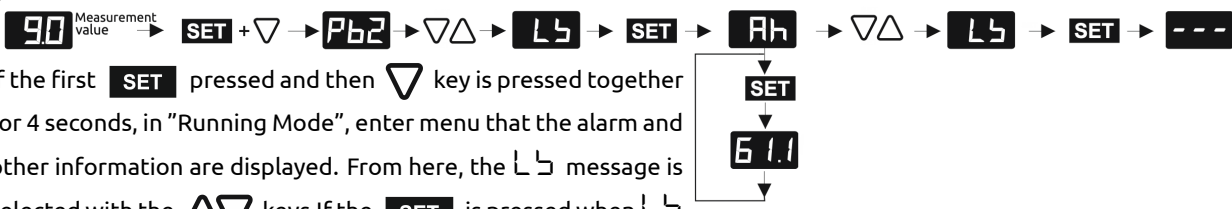

If the first **SET** pressed and then ∇ key is pressed together for 4 seconds, in "Running Mode", enter menu that the alarm and other information are displayed. From here, the $L5$ message is selected with the $\triangle \nabla$ keys. If the **SET** is pressed when $L5$ is displayed, the alarm that occurs is cleared.

Displaying Compressor Operating Time



If the first **SET** pressed and then **▽** key is pressed together for 4 seconds, in "Running Mode", enter menu that the alarm and other information are displayed. From here, the **c h** message is selected with the **▽ Δ** keys. Pressing the **SET** key will display the running time of the compressor. When the **c h** message is displayed and you want to return to the running mode at any point in the operation, you must press the **⏻** or no key for 15 seconds without pressing any key. The compressor run time can be stored up to 999 hours.

Resetting Compressor Operating Time



If the first **SET** pressed and then **▽** key is pressed together for 4 seconds, in "Running Mode", enter menu that the alarm and other information are displayed. From here, the **r c h** message is selected with the **▽ Δ** keys. **SET** is pressed key and adjusted the password to 149. The message **---** is displayed and the compressor running time is reset. When the **r c h** message is displayed and you want to return to the running mode at any point in the operation, you must press the **⏻** or no key for 15 seconds without pressing any key.

Restoring Factory Settings

When the security parameter **P A** is set to **-44**, if the **▽** button is pressed for 6 seconds, the **d F** message is displayed and the operation mode returns to factory settings.

Displaying Revision Date

If the **⚙️ Δ** button is held down first while in operation mode, and then the **A F ▽** button is pressed, the revision date is displayed as YY/MM/DD.

Changing Parameter Values

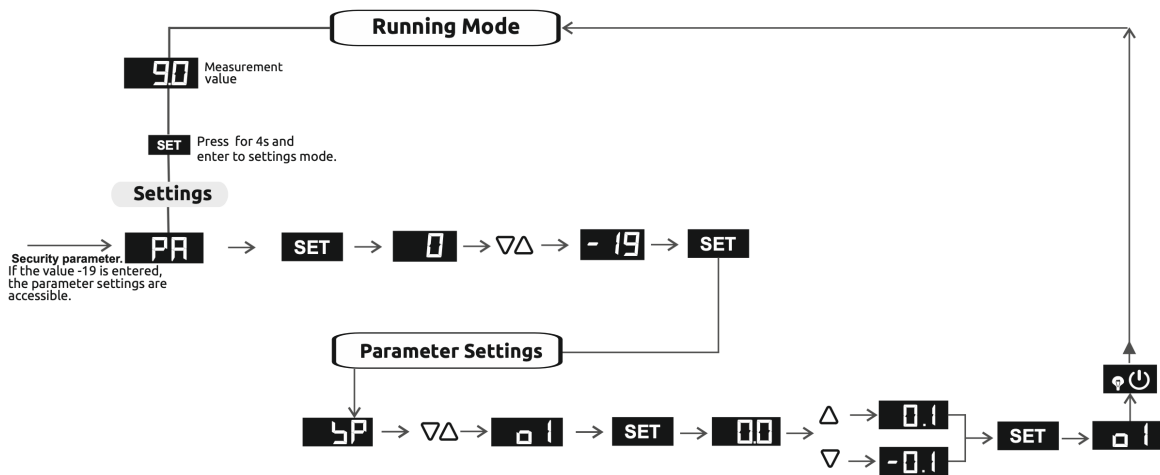

If the **SET** key is pressed for 4 seconds in the Running Mode, the password (**PR**) message is displayed on the display. By pressing the **SET** key, the password is set to " - 19 " with the Δ ∇ keys and the **SET** key is pressed, then the parameter menu is entered. By scrolling through the menu with the Δ ∇ keys, when the desired parameter setting message is displayed, if the **SET** key is pressed, the value of that parameter is displayed. The value of the relevant parameter can be changed with the Δ ∇ keys. If no operation is performed while the parameter value is displayed, after 3 seconds, or if the **SET** key is pressed, the name of the parameter is returned. If the ⏻ key is pressed while the parameter name is displayed, this time will be exited without waiting.

LEDs and Key Definitions



LED Definitions		Key Definitions	
	On/Off LED Does not illuminate when the device is ON; illuminates when it is OFF.		Set Key - Shows set value in operating mode, enters parameter menu, - Displays selected parameter value in programming mode, confirms changed parameter value.
	Compressor LED Illuminates when the compressor is operating; blinks when protection delays are active; turns off when not operating.		Up Key - Starts manual defrost if conditions allow in operating mode, - Switches between parameters in programming mode, increases the value of the selected parameter.
	Defrost LED Illuminates during defrosting; blinks when protection delays and drip-drain times are active; turns off when not operating.		Down Key - In operating mode, if $rS = 0$ and $rB = 1$, initiates rapid cooling; if $rS = 1$ and $rB = 1$, initiates rapid heating; if $rS = 0$ and $rB = 2$, initiates energy-saving mode, - Switches between parameters in programming mode, decreases the value of the selected parameter.
	Evaporator Fan LED Illuminates when the evaporator fan output is active; remains off when not operating.		On/Off Key - Turns the device on/off or switches the lighting output on/off in operating mode, - Returns to operating mode from parameter menu in programming mode.
AUX	Aux LED Illuminates when the auxiliary output is active; remains off when not operating.		
°C	Celsius LED Illuminates when the temperature unit is set to °C (Celsius).		
°F	Fahrenheit LED Illuminates when the temperature unit is set to °F (Fahrenheit).		
HACCP	HACCP Alarm LED Blinks when a new alarm occurs; illuminates if the last alarm was acknowledged; turns off once all alarms are acknowledged.		
	Energy Saving LED Illuminates when energy-saving mode is active; remains off otherwise.		
	Compressor Maintenance LED Illuminates when the compressor has reached its working time limit.		
	Rapid Cooling/Heating LED Illuminates during rapid cooling/heating.		
	Alarm/Error LED Illuminates during alarm states and sensor errors.		

Error - Warning - Alarm Definitions

	Definition	Outputs
P _{r1}	Cabin Probe Error - Check the cabin probe connection. - The compressor operates according to parameters C4 and C5.	All outputs are turned off.
P _{r2}	Evaporator Probe Error - Check evaporator probe connection. - Check parameter P4.	Defrost output is turned off
P _{r3}	Condenser Probe Error - Check condenser probe connection.	The condenser fan output is turned off.
AL	Low Temperature Alarm - Check parameters A0, A1, and A2.	The outputs remain unchanged.
Ah	High Temperature Alarm - Check parameters A0, A4 and A5.	The outputs remain unchanged.
i _d	Door Open Alarm - Check the door digital input. - Check parameters i0 and i1.	Check the i0 parameter.
i _A	Multi-Function Input Alarm - Check the multi-function digital input. - Check parameters i5 and i6.	Check the i5 parameter.
LP	Low Pressure Alarm - Check parameters i5 and i6.	The outputs remain unchanged.
i _h	High Pressure Alarm - Check parameters i5 and i6.	The outputs remain unchanged.
c _{oh}	Condenser Probe Overheating Alarm - Check the condenser probe. - Check parameter C6.	The outputs remain unchanged.
c _{hd}	Condenser Probe Overheating After Compressor Shutdown Alarm - Check the condenser probe. - Check parameter C7.	Compressor output is turned off.
d _{Fd}	Defrost Alarm	The outputs remain unchanged.

EOU	Connection Error Message Between User Interface and Control Module	The outputs remain unchanged.
LOC	Key Lock Message - See Key Lock Operations to change key lock settings.	The outputs remain unchanged.
UNL	Key Lock Released Message - See Key Lock Operations to change key lock settings.	The outputs remain unchanged.
DF	Factory Reset Message - The device will start working according to factory settings.	—
SrS	Service Alarm - Check parameters S1 and S2.	All outputs are turned off.

Configuration Parameters

Display	Description	Min	Max	Unit	Default
SEt	Set value	r 1	r 2	°C/°F	4
cA 1	Cabinet probe offset value	-25	25	-	0
cA2	Evaporator probe offset value	-25	25	-	0
cA3	Auxiliary probe offset value	-25	25	-	0
P 1	Decimal point 0: No 1: Yes	0	1	-	0
P2	Temperature unit °C: Celcius °F: Fahrenheit	°C	°F	-	°C
P3	Evaporator probe function 0: Not used 1: Used for defrost and fan control 2: Used for fan control only	0	2	-	1
P4	Condenser probe use 0: Not used 1: Used	0	1	-	0

Display	Description	Min	Max	Unit	Default
P5	Value displayed 0: cabinet temperature 1: setpoint 2: evaporator temperature 3: auxiliary temperature	0	3	-	0
P8	Display refresh time	1	250	ds	1
r0	Setpoint differential	1	20	-	3
r1	Setpoint lower limit	-60	r2	°C/°F	-40
r2	Setpoint upper limit	r1	150	°C/°F	50
r3	Enable setpoint lock 0: Disable setpoint lock 1: Enable setpoint lock	0	1	-	0
r4	Setpoint offset in energy saving	0	99	°C/°F	0
r5	Type of control mode 0: Cold mode 1: Hot mode	0	1	-	0
r6	Setpoint offset in overcooling/overheating	0	99	°C/°F	0
r7	Duration overcooling/overheating	0	240	min	2
r8	Down key additional function 0: disabled 1: overcooling/overheating 2: energy saving	0	2	-	2

Compressor Protection Parameters

Display	Description	Min	Max	Unit	Default
c0	Compressor-on delay from power-on	0	240	min	0
c2	Minimum compressor-off time	0	240	min	3
c3	Minimum compressor-on time (sec)	0	240	-	0
c4	Compressor-off time in cabinet probe alarm	0	240	min	10
c5	Compressor-on time in cabinet probe alarm	0	240	min	10
c6	If the condenser temperature is higher than this value, the condenser temperature alarm 'COH' becomes active	0	150	°C/°F	80

Display	Description	Min	Max	Unit	Default
c7	If the condenser temperature is higher than this value, the condenser temperature alarm 'Csd' becomes active	0	150	°C/°F	90
c8	Csd alarm delay	0	15	min	1
c10	Compressor run time limit. When the compressor runs for more than this time, the maintenance led turns on	0	999	hr	0

Defrost Control Parameters

Display	Description	Min	Max	Unit	Default
d0	Automatic defrost interval	0	99	hr	8
d1	Type of defrost 0: Electric (Compressor off) defrost 1: Hot gas (compressor on) defrost 2: Compressor stopped	0	2	-	0
d2	Defrost end threshold (P3 must be 1)	-60	150	°C/°F	2
d3	Defrost duration	0	99	min	30
d4	Defrost starts with energy 0: Defrost does not start with energy 1: Defrost starts with energy	0	1	-	0
d5	Defrost delay from power-on	0	99	min	0
d6	Value displayed when defrosting 0: The cabin temperature is displayed 1: Locked display 2: During defrost, "DEF" message is displayed	0	2	-	1
d7	Dripping time	0	15	min	4
d8	Defrost interval count mode 0: The time counter (d0) between two defrosts is decremented regardless of any condition 1: The time counter (d0) between two defrosts is decremented only as long as the compressor is running 2: The time counter (d0) between two defrosts is decremented only as long as the evaporator probe temperature is less than d9 par. (P2 < d9) 3: Adaptive defrost	0	3	-	0

Display	Description	Min	Max	Unit	Default
d9	Evaporation threshold for automatic defrost interval count (when d8=2)	-60	99	°C/°F	0
d11	Defrost alarm max. is turned off if the display time has been reached 0: The defrost alarm is not turned off 1: The defrost alarm is turned off	0	1	-	0
d15	Compressor-on consecutive time for hot gas defrost (when d1=1)	0	99	min	0
d16	Pre-dripping time for hot gas defrost	0	99	min	0
d18	In defrost normal operation mode, if the sum of the times during which the evaporator temperature is below the calculated ideal evaporation temperature reaches this time, defrost is activated	0	99	min	40
d19	Defrost is active if the evaporator probe temperature (calculated evap temperature-d19) is lower than this value	0	150	°C/°F	3
d22	Adaptive defrost evap probe termination temperature	-10	10	°C/°F	-2

Alarm Control Parameters

Display	Description	Min	Max	Unit	Default
A0	Select value for high/low temperature alarms 0: Cabinet probe 1: Evaporator probe	0	1	-	0
A1	Low temperature alarm threshold	A4	99	°C/°F	-50
A2	Type of low temperature alarm 0: Disabled 1: The alarm activation value becomes SP- A1 2: The alarm activation value becomes A1	0	2	-	2
A4	High temperature alarm threshold	-60	A1	°C/°F	60
A5	Type of high temperature alarm 0: Disabled 1: Alarm activation value becomes SP+A4 2: The alarm activation value becomes A4	0	2	-	2
A6	High temperature alarm delay from power-on	0	240	min	120
A7	High/low temperature alarm delay	0	240	min	15

Display	Description	Min	Max	Unit	Default
A8	High temperature alarm delay post-defrosting	0	240	min	15
A9	High temperature alarm delay from door closure	0	240	min	15
A11	High/low temperature alarm reset differential	1	15	-	2
S1	Service alarm set value	-60	150	°C/°F	65
S2	Service alarm stop value	-60	150	°C/°F	50

Fan Control Parameters

Display	Description	Min	Max	Unit	Default
F0	Evaporator fan mode in normal function 0: Off 1: On 2: On if compressor on 3: Thermoregulated(with room temperature + F1) 4: Thermoregulated(with room temperature + F1) if compressor on 5: Function of F6 6: Thermoregulated(with F1) 7: Thermoregulated(with F1) if compressor on	0	7	-	1
F1	Evaporator fan regulation threshold	-60	150	°C/°F	-4
F2	Evaporator fan mode in defrost and drip mode 0: Off 1: On 2: Dependent function of F0	0	2	-	0
F3	Post-dripping delay of the evap. fan	0	15	min	2
F4	Time evaporator fan off in energy saving	0	240	sec	30
F5	Time evaporator fan on in energy saving	0	240	-	30
F6	Function for high/low humidity 0: For low humidity (with F17 and F18 if compressor off, on if compressor on) 1: For high humidity(on)	0	1	-	0
F7	Evaporator fans on threshold from dripping (relative to setpoint)	-60	99	°C/°F	5
F8	Evaporator fan regulation threshold differential	1	20	-	2
F9	Evaporator fan off delay from compressor off(if F0 = 2 or 5)	0	240	sec	10

Display	Description	Min	Max	Unit	Default
F 11	Condenser fan on threshold according to condenser probe	0	99	°C/°F	15
F 12	Condenser fan off delay from compressor off	0	240	sec	30
F 17	Time evaporator fan off in low humidity	0	240	sec	60
F 18	Time evaporator fan on in low humidity	0	240	sec	10

Digital Input Parameters

Display	Description	Min	Max	Unit	Default
i0	Door switch input functions 0: Disabled 1: Compressor and evap. fan off 2: Evap. fan off 3: Cabinet light on 4: Compressor and evap. fan off, cabinet light on 5: Evap. fan off, cabinet light on	0	5	-	5
i1	Door digital input activation 0: N.O. 1: N.C.	0	1	-	0
i2	Door open alarm delay	0	120	min	30
i3	Max. time for inhibiting regulation with door open	0	120	min	15
i4	Door digital input alarm storage 0: Passive 1: Active	0	1	-	0
i5	Multi-purpose input function 0: Disabled 1: Energy saving 2: Alarm iA 3: Alarm iSd 4: Enable aux output 5: Switches device on/off 6: Alarm LP	0	6	-	0
i6	Multifunction digital input activation 0: N.O. 1: N.C.	0	1	-	0
i7	Multi-purpose input alarm delay	0	120	min	0

Display	Description	Min	Max	Unit	Default
i8	Number of multi-purpose input activations for high pressure alarm(if i5 = 3)	0	15	-	0
i9	Counter reset time for high pressure alarm	1	999	min	240
i10	Door closed consecutive time for energy saving	0	999	min	0

AUX Output Parameters

Display	Description	Min	Max	Unit	Default
u1	Aux relay control 0: As a lighting output (i0 and u2 must be controlled) 1: As a demister output (must check u6 par) 2: As AUX output (u2 must be checked) 3: As alarm output (u4 must be checked) 4: As evaporator output (u7 and u8 should be checked) 5: As the condenser fan output according to the condenser temperature (P4, F11, F12 should be checked)	0	5	-	0
u2	Activating the lighting and AUX outputs on and off when the device is manually off/on 0: Passive 1: Active	0	1	-	0
u4	Enable silencing alarm output 0: Passive 1: Active	0	1	-	1
u6	Duration demisting on	1	120	min	5
u7	In order for the evaporator output to be active, the cabin temperature must be above this adjusted parameter	0	99	°C/°F	2
u8	Evaporatör output activation 0: N.O. 1: N.C.	0	1	-	0
u9	Enable alarm buzzer 0: Passive 1: Active	0	1	-	0

Modbus Communication Parameters

Display	Description	Min	Max	Unit	Default
h1	Modbus slave device address	1	247	-	1
h2	Baud rate 0: OFF 1: 1200 bps 2: 2400 bps 3: 4800 bps 4: 9600 bps 5: 19200 bps 6: 38400 bps 7: 56000 bps 8: 57600 bps 9: 115200 bps	0	9	bps	4

Energy Saving Parameters

Display	Description	Min	Max	Unit	Default
hE2	Maximum duration energy saving (if it's 0 then it is until door opened)	0	999	min	2

ESDC3034 Split Digital Thermostat Modbus Map

Holding Registers

Register Addresses		Data Type	Description	Display	Permission
Decimal	Hex				
0	0x0000	word	Set value [°C/°F]	SEt	Readable Writable
1	0x0001	word	Cabinet probe offset value	cA1	Readable Writable
2	0x0002	word	Evaporator probe offset value	cA2	Readable Writable
3	0x0003	word	Auxiliary probe offset value	cA3	Readable Writable
4	0x0004	word	Evaporator probe function 0: Not used 1: Used for defrost and fan control 2: Used for fan control only	P3	Readable Writable
5	0x0005	word	Value displayed 0: cabinet temperature 1: setpoint 2: evaporator temperature 3: auxiliary temperature	PS	Readable Writable
6	0x0006	word	Display refresh time [ds]	P8	Readable Writable
7	0x0007	word	Setpoint differential	r0	Readable Writable
8	0x0008	word	Setpoint lower limit [°C/°F]	r1	Readable Writable
9	0x0009	word	Setpoint upper limit [°C/°F]	r2	Readable Writable
10	0x000A	word	Setpoint offset in energy saving [°C/°F]	r4	Readable Writable
11	0x000B	word	Setpoint offset in overcooling/overheating [°C/°F]	r6	Readable Writable
12	0x000C	word	Duration overcooling/overheating [min]	r7	Readable Writable
13	0x000D	word	Down key additional function 0: disabled 1: overcooling/overheating 2: energy saving	r8	Readable Writable
14	0x000E	word	Compressor-on delay from power-on [min]	c0	Readable Writable

Register Addresses		Data Type	Description	Display	Permission
Decimal	Hex				
15	0x000F	word	Minimum compressor-off time [min]	c2	Readable Writable
16	0x0010	word	Minimum compressor-on time (sec)	c3	Readable Writable
17	0x0011	word	Compressor-off time in cabinet probe alarm [min]	c4	Readable Writable
18	0x0012	word	Compressor-on time in cabinet probe alarm [min]	c5	Readable Writable
19	0x0013	word	If the condenser temperature is higher than this value, the condenser temperature alarm 'COH' becomes active [°C/°F]	c6	Readable Writable
20	0x0014	word	If the condenser temperature is higher than this value, the condenser temperature alarm 'Csd' becomes active [°C/°F]	c7	Readable Writable
21	0x0015	word	CSd alarm delay [min]	c8	Readable Writable
22	0x0016	word	Compressor run time limit. When the compressor runs for more than this time, the maintenance led turns on [hr]	c10	Readable Writable
23	0x0017	word	Automatic defrost interval [hr]	d0	Readable Writable
24	0x0018	word	Type of defrost 0: Electric (Compressor off) defrost 1: Hot gas (compressor on) defrost 2: Compressor stopped	d1	Readable Writable
25	0x0019	word	Defrost end threshold (P3 must be 1) [°C/°F]	d2	Readable Writable
26	0x001A	word	Defrost duration [min]	d3	Readable Writable
27	0x001B	word	Defrost delay from power-on [min]	d5	Readable Writable
28	0x001C	word	Value displayed when defrosting 0: The cabin temperature is displayed 1: Locked display 2: During defrost, "dEF" message is displayed	d6	Readable Writable
29	0x001D	word	Dripping time [min]	d7	Readable Writable

Register Addresses		Data Type	Description	Display	Permission
Decimal	Hex				
30	0x001E	word	Defrost interval count mode 0: The time counter (d0) between two defrosts is decremented regardless of any condition 1: The time counter (d0) between two defrosts is decremented only as long as the compressor is running 2: The time counter (d0) between two defrosts is decremented only as long as the evaporator probe temperature is less than d9 par. (P2 < d9) 3: Adaptive defrost	d8	Readable Writable
31	0x001F	word	Evaporation threshold for automatic defrost interval count (when d8=2) [°C/°F]	d9	Readable Writable
32	0x0020	word	Compressor-on consecutive time for hot gas defrost (when d1=1) [min]	d15	Readable Writable
33	0x0021	word	Pre-dripping time for hot gas defrost [min]	d16	Readable Writable
34	0x0022	word	In defrost normal operation mode, if the sum of the times during which the evaporator temperature is below the calculated ideal evaporation temperature reaches this time, defrost is activated [min]	d18	Readable Writable
35	0x0023	word	Defrost is active if the evaporator probe temperature (calculated evap temperature-d19) is lower than this value [°C/°F]	d19	Readable Writable
36	0x0024	word	Adaptive defrost evap probe termination temperature [°C/°F]	d22	Readable Writable
37	0x0025	word	Low temperature alarm threshold [°C/°F]	A1	Readable Writable
38	0x0026	word	Type of low temperature alarm 0: Disabled 1: The alarm activation value becomes SP- A1 2: The alarm activation value becomes A1	A2	Readable Writable
39	0x0027	word	High temperature alarm threshold [°C/°F]	A4	Readable Writable
40	0x0028	word	Type of high temperature alarm 0: Disabled 1: Alarm activation value becomes SP+A4 2: The alarm activation value becomes A4	A5	Readable Writable
41	0x0029	word	High temperature alarm delay from power-on [min]	A6	Readable Writable
42	0x002A	word	High/low temperature alarm delay [min]	A7	Readable Writable

Register Addresses		Data Type	Description	Display	Permission
Decimal	Hex				
43	0x002B	word	High temperature alarm delay post-defrosting [min]	A8	Readable Writable
44	0x002C	word	High temperature alarm delay from door closure [min]	A9	Readable Writable
45	0x002D	word	High/low temperature alarm reset differential	A11	Readable Writable
46	0x002E	word	Service alarm set value [°C/°F]	B1	Readable Writable
47	0x002F	word	Service alarm stop value [°C/°F]	B2	Readable Writable
48	0x0030	word	Evaporator fan mode in normal function 0: Off 1: On 2: On if compressor on 3: Thermoregulated(with room temperature + F1) 4: Thermoregulated(with room temperature + F1) if compressor on 5: Function of F6 6: Thermoregulated(with F1) 7: Thermoregulated(with F1) if compressor on	F0	Readable Writable
49	0x0031	word	Evaporator fan regulation threshold [°C/°F]	F1	Readable Writable
50	0x0032	word	Evaporator fan mode in defrost and drip mode 0: Off 1: On 2: Dependent function of F0	F2	Readable Writable
51	0x0033	word	Post-dripping delay of the evap. fan [min]	F3	Readable Writable
52	0x0034	word	Time evaporator fan off in energy saving [sec]	F4	Readable Writable
53	0x0035	word	Time evaporator fan on in energy saving	F5	Readable Writable
54	0x0036	word	Function for high/low humidity 0: For low humidity (with F17 and F18 if compressor off, on if compressor on) 1: For high humidity(on)	F6	Readable Writable
55	0x0037	word	Evaporator fans on threshold from dripping (relative to setpoint) [°C/°F]	F7	Readable Writable
56	0x0038	word	Evaporator fan regulation threshold differential	F8	Readable Writable

Register Addresses		Data Type	Description	Display	Permission
Decimal	Hex				
57	0x0039	word	Evaporator fan off delay from compressor off(if F0 = 2 or 5) [sec]	F9	Readable Writable
58	0x003A	word	Condenser fan on threshold according to condenser probe [°C/°F]	F11	Readable Writable
59	0x003B	word	Condenser fan off delay from compressor off [sec]	F12	Readable Writable
60	0x003C	word	Time evaporator fan off in low humidity [sec]	F17	Readable Writable
61	0x003D	word	Time evaporator fan on in low humidity [sec]	F18	Readable Writable
62	0x003E	word	Door switch input functions 0: Disabled 1: Compressor and evap. fan off 2: Evap. fan off 3: Cabinet light on 4: Compressor and evap. fan off, cabinet light on 5: Evap. fan off, cabinet light on	i0	Readable Writable
63	0x003F	word	Door open alarm delay [min]	i2	Readable Writable
64	0x0040	word	Max. time for inhibiting regulation with door open [min]	i3	Readable Writable
65	0x0041	word	Multi-purpose input function 0: Disabled 1: Energy saving 2: Alarm iA 3: Alarm iSd 4: Enable aux output 5: Switches device on/off 6: Alarm LP	i5	Readable Writable
66	0x0042	word	Multi-purpose input alarm delay [min]	i7	Readable Writable
67	0x0043	word	Number of multi-purpose input activations for high pressure alarm(if i5 = 3)	i8	Readable Writable
68	0x0044	word	Counter reset time for high pressure alarm [min]	i9	Readable Writable
69	0x0045	word	Door closed consecutive time for energy saving [min]	i10	Readable Writable

Register Addresses		Data Type	Description	Display	Permission
Decimal	Hex				
70	0x0046	word	Aux relay control 0: As a lighting output (i0 and u2 must be controlled) 1: As a demister output (must check u6 par) 2: As AUX output (u2 must be checked) 3: As alarm output (u4 must be checked) 4: As evaporator output (u7 and u8 should be checked) 5: As the condenser fan output according to the condenser temperature (P4, F11, F12 should be checked)	u1	Readable Writable
71	0x0047	word	Duration demisting on [min]	u6	Readable Writable
72	0x0048	word	In order for the evaporator output to be active, the cabin temperature must be above this adjusted parameter [°C/°F]	u7	Readable Writable
73	0x0049	word	Maximum duration energy saving (if it's 0 then it is until door opened) [min]	hE2	Readable Writable
74	0x004A	word	Modbus slave device address	h1	Readable Writable
75	0x004B	word	Baud rate [bps] 0: OFF 1: 1200 bps 2: 2400 bps 3: 4800 bps 4: 9600 bps 5: 19200 bps 6: 38400 bps 7: 57600 bps 8: 115200 bps	h2	Readable Writable

Coils

Register Addresses		Data Type	Description	Display	Permission
Decimal	Hex				
0	0x0000	bit	Decimal point 0: No 1: Yes	P1	Readable Writable
1	0x0001	bit	Temperature unit 0: Celcius 1: Fahrenheit	P2	Readable Writable
2	0x0002	bit	Condenser probe use 0: Used 1: Not used	P4	Readable Writable

Register Addresses		Data Type	Description	Display	Permission
Decimal	Hex				
3	0x0003	bit	Enable setpoint lock 0: Disable setpoint lock 1: Enable setpoint lock	r3	Readable Writable
4	0x0004	bit	Type of control mode 0: Cold mode 1: Hot mode	r5	Readable Writable
5	0x0005	bit	Defrost starts with energy 0: Defrost does not start with energy 1: Defrost starts with energy	d4	Readable Writable
6	0x0006	bit	Defrost alarm max. is turned off if the display time has been reached 0: The defrost alarm is not turned off 1: The defrost alarm is turned off	d11	Readable Writable
7	0x0007	bit	Select value for high/low temperature alarms 0: Cabinet probe 1: Evaporator probe	R0	Readable Writable
8	0x0008	bit	Door digital input activation 0: N.O. 1: N.C.	i1	Readable Writable
9	0x0009	bit	Door digital input alarm storage 0: Passive 1: Active	i4	Readable Writable
10	0x000A	bit	Multifunction digital input activation 0: N.O. 1: N.C.	i6	Readable Writable
11	0x000B	bit	Activating the lighting and AUX outputs on and off when the device is manually off/on 0: Passive 1: Active	u2	Readable Writable
12	0x000C	bit	Enable silencing alarm output 0: Passive 1: Active	u4	Readable Writable
13	0x000D	bit	Evaporatör output activation 0: N.O. 1: N.C.	u8	Readable Writable
14	0x000E	bit	Enable alarm buzzer 0: Passive 1: Active	u9	Readable Writable

Register Addresses		Data Type	Description	Display	Permission
Decimal	Hex				
15	0x000F	bit	Fast cooling 0: Overcooling passive 1: Overcooling active		Readable Writable
16	0x0010	bit	Starting/stopping manual defrost 0: Manual defrost passive 1: Manual defrost active		Readable Writable
17	0x0011	bit	Device manual switch on/off 0: Device is on 1: Device is off		Readable Writable
18	0x0012	bit	Loading default parameters 0: Passive 1: Active		Readable Writable
19	0x0013	bit	Clearing generated HACCP alarms 0: Passive 1: Active		Readable Writable
20	0x0014	bit	Compressor runtime reset 0: Passive 1: Active		Readable Writable
21	0x0015	bit	Aux relay control 0: Passive 1: Active		Readable Writable
22	0x0016	bit	Alarm silence control 0: Passive 1: Active		Readable Writable
23	0x0017	bit	Key lock control 0: Passive 1: Active		Readable Writable
24	0x0018	bit	Defrost alarm silence control 0: Passive 1: Active		Readable Writable
25	0x0019	bit	HACCP new alarm control 0: Passive 1: Active		Readable Writable
26	0x001A	bit	Energy saving mode 0: Energy saving passive 1: Energy saving active		Readable Writable

Register Addresses		Data Type	Description	Display	Permission
Decimal	Hex				
27	0x001B	bit	Fast heating 0: Overheating passive 1: Overheating active		Readable Writable
28	0x001C	bit	Relay output test 0: Relay outputs passive 1: Relay outputs active		Readable Writable

Discrete Inputs

Register Addresses		Data Type	Description	Display	Permission
Decimal	Hex				
0	0x0000	bit	Control output status (0 = OFF, 1 = ON)		Readable
1	0x0001	bit	Defrost output status (0 = OFF, 1 = ON)		Readable
2	0x0002	bit	Fan output status (0 = OFF, 1 = ON)		Readable
3	0x0003	bit	Aux output status (0 = OFF, 1 = ON)		Readable
4	0x0004	bit	Compressor run time limit control (1 = Run limit exceeded)		Readable
5	0x0005	bit	dFd alarm status (0 = OFF, 1 = ON)		Readable
6	0x0006	bit	Message before melting		Readable

Input Registers

Register Addresses		Data Type	Description	Display	Permission
Decimal	Hex				
0	0x0000	word	Measured cabinet temperature value(°C / °F)		Readable
1	0x0001	word	Measured evaporator probe temperature value(°C / °F)		Readable
2	0x0002	word	Measured condenser probe temperature value(°C / °F)		Readable
3	0x0003	word	Cabinet probe error status		Readable
4	0x0004	word	Evap. probe error status		Readable
5	0x0005	word	Condenser probe error status		Readable
6	0x0006	word	HACCP AH alarm temperature value(°C / °F)		Readable
7	0x0007	word	HACCP AL alarm temperature value(°C / °F)		Readable
8	0x0008	word	Duration of HACCP AH alarm [min]		Readable
9	0x0009	word	Duration of HACCP AL alarm[min]		Readable

Register Addresses		Data Type	Description	Display	Permission
Decimal	Hex				
10	0x000A	word	Duration of HACCP ID alarm[min]		Readable
11	0x000B	word	Condenser probe overheat alarm		Readable
12	0x000C	word	Compressor shutdown alarm after condenser probe warms up		Readable
13	0x000D	word	HACCP Alarm status		Readable
14	0x000E	word	Service alarm status		Readable
15	0x000F	word	Alarm status		Readable
16	0x0010	word	Compressor running time[min]		Readable
17	0x0011	word	Compressor running time(hour)		Readable
18	0x0012	word	Compressor status information		Readable
19	0x0013	word	Defrost status information		Readable
20	0x0014	word	Fan status information		Readable
21	0x0015	word	AUX status information		Readable
22	0x0016	word	Digital input status information		Readable
23	0x0017	word	Multifunction input status information		Readable